

DIAVIB-PRO

Asset Monitoring System

PREDICTIVE MAINTENANCE AND VIBRATION ANALYSIS

- Supports the CUBE triaxial vibration sensor
- Integrates CEMB vibration monitoring systems such as TD-2 and TDSP
- Reads all types of Analog or Digital sensors
- Correlates vibrations with process measurements
- Manages the most common communication protocols (MODBUS, OPC-UA...)
- Compliant with cybersecurity regulations

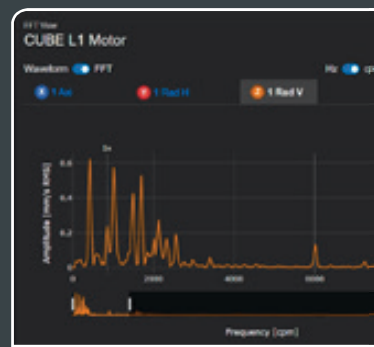

More saving

Reduce consumption
Lower operating costs
Eliminate insurance costs



More Productivity

Prevent problems
Extend service life
Increase performance
Improve efficiency



Targeted maintenance

View status
Identify problems
Reduce external interventions
Avoid breakdowns

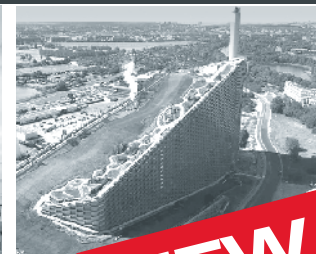
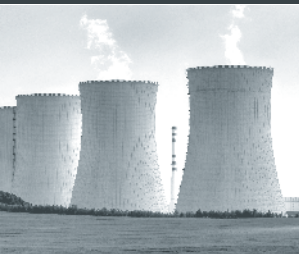

NEW

SIMPLE INSTALLATION,
IMMEDIATE DIAGNOSIS,
MAXIMUM RELIABILITY:
DIAGNOSIS AND MAINTENANCE BECOME INTELLIGENT



CEMB

VIBRATION EQUIPMENT

DIIVIB-PRO

Asset Monitoring System

DIIVIB-PRO is a turnkey system for plant monitoring and predictive diagnosis. It has a local FIFO memory of 25GB and the ability to save measurements based on time or events, enabling analysis and visualization of trends, FFT, Waveform, and Orbits over long periods.

The **PROVIB** analysis software is included in the system, does not require licenses, and can be updated locally or remotely. It is designed for Cloud use, with the latest security certificates and advanced AI algorithms.

DIIVIB-PRO is simple and modular: it works both in stand-alone mode, directly connecting up to 8 **CUBE** triaxial sensors, and by interfacing other **DIIVIB** control units via Ethernet, expanding its capabilities.

Not just vibrations:

DIIVIB-PRO correlates vibrations and process measurements: The system acquires every physical quantity from field sensors through communication protocols and analog and digital I/O.

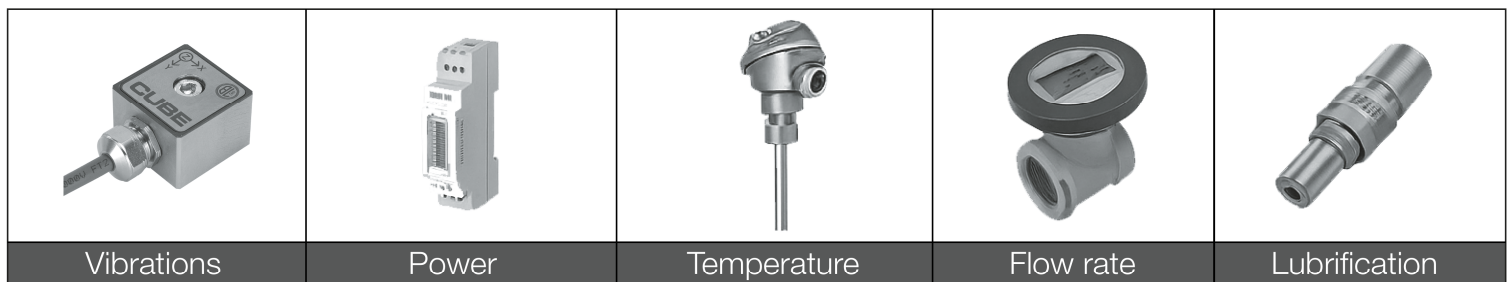

Interface with Supervisors, PLC, and Field Sensors

The core of DIIVIB-PRO is VIB_EDGE, a powerful edge computer that offers large memory capacity, I/O, communication ports, and an integrated web-based user interface.

In addition to common serial ports, it features 2 RJ45 Ethernet ports and Wi-Fi: the supervision network and the field are separated and protected. DIIVIB-PRO implements the most common and secure communication protocols.

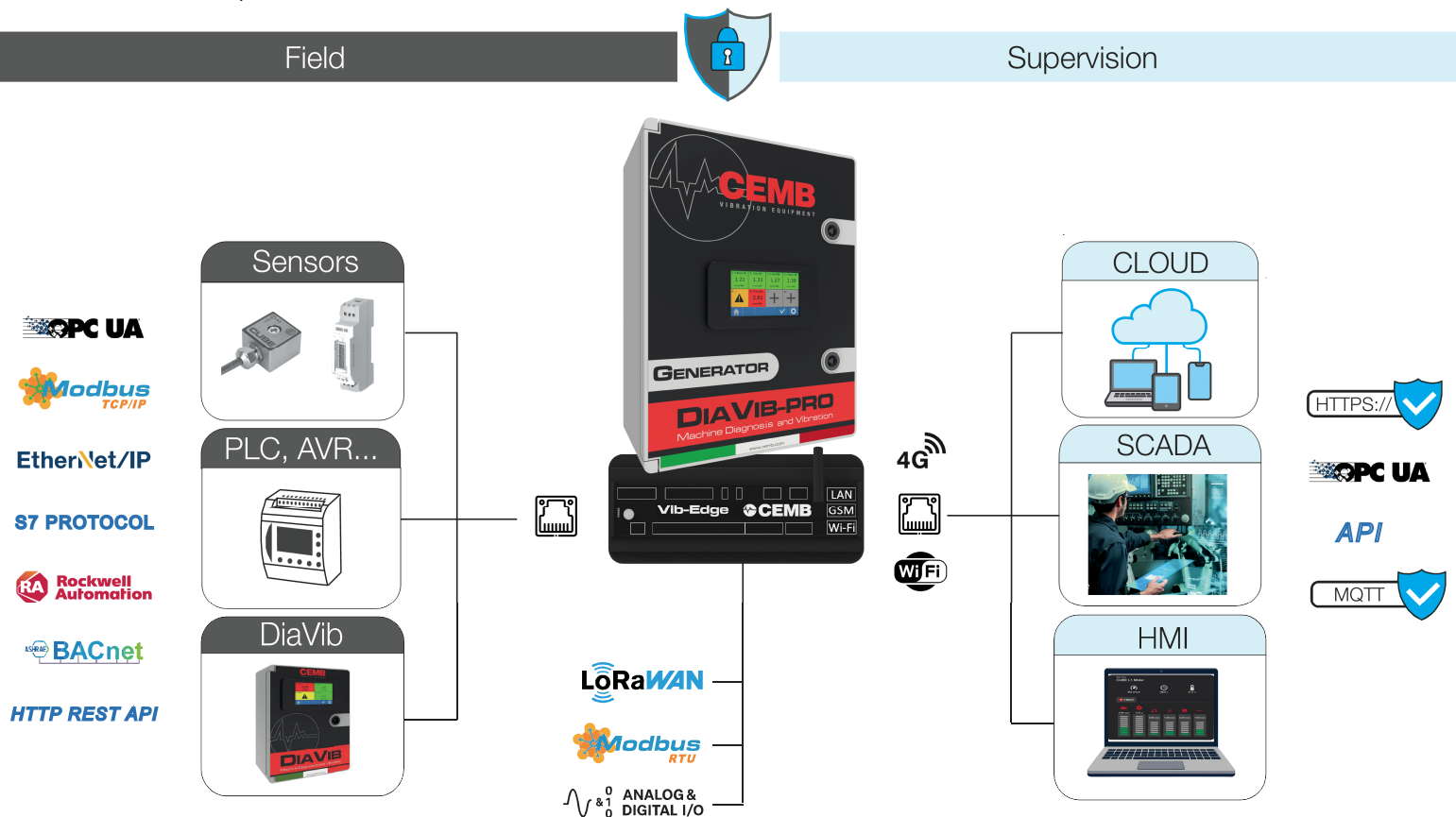

Inside DIAVIB-PRO:

PROVIB vibration analysis dashboard

PROVIB is the web-based vibration analysis software integrated into VibEdge. It does not require licenses or installations; simply connect to the Ethernet port of Diavib-Pro and launch the web browser to analyze the machine with an intuitive and immediate interface that simplifies even the most complex vibration analyses. By activating the Cloud subscription, it is possible to access the system remotely via PC or smartphone, receive SMS or email alerts, and manage updates and new features released. The system uses dual-key security and allows three levels of password-protected access.

DIAGNOSTIC

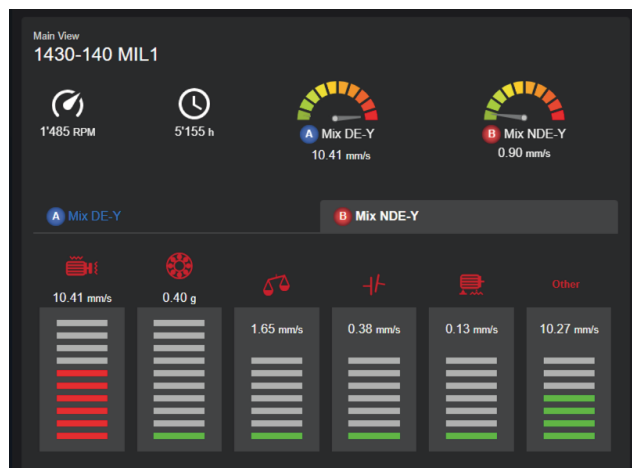

TREND

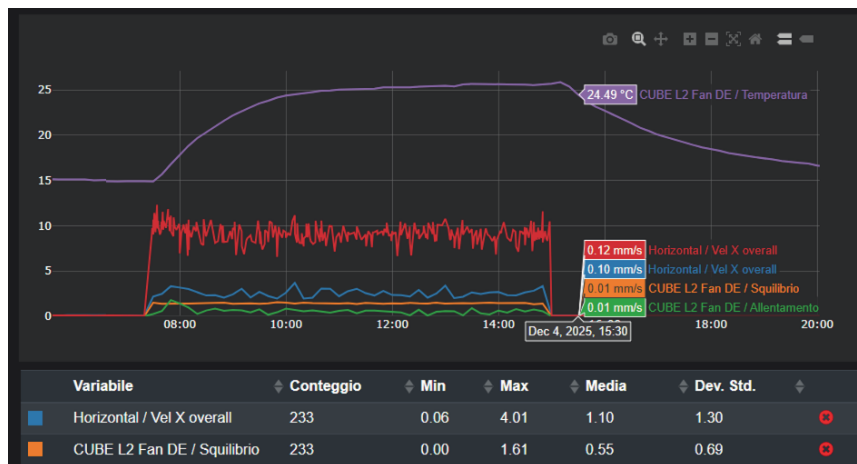

FFT

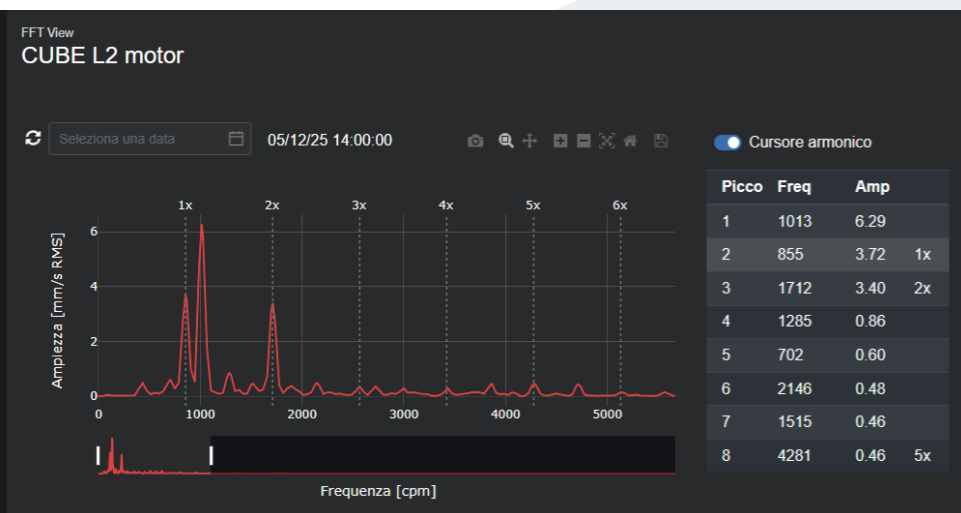

WATERFALL

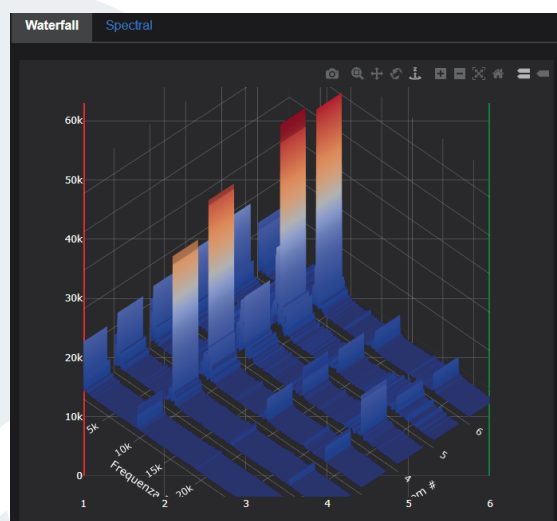

WAVEFORM

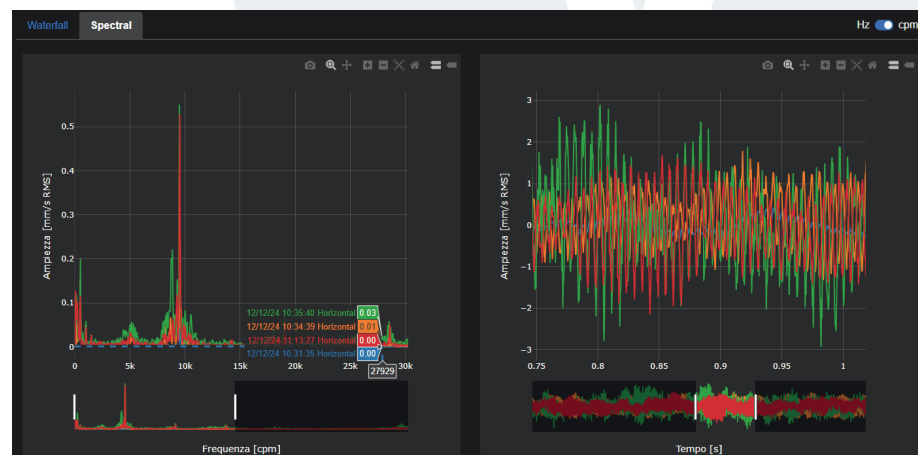

And much more...

- Machine synoptic view
- Vibration orbit analysis
- Threshold and delay settings Data
- Export in .XLS format
- Customization of logic and graphs
- Navigation of measurements over time
- Management of saving criteria
- Direct device access via VPN

Ordering Information

DIAVIB-PRO / **A** / **B**

A: DISPLAY

0: No Display
1: 4,3" Touch Display

B: MODEM 4G*

0: No Modem
1: With integrated Modem

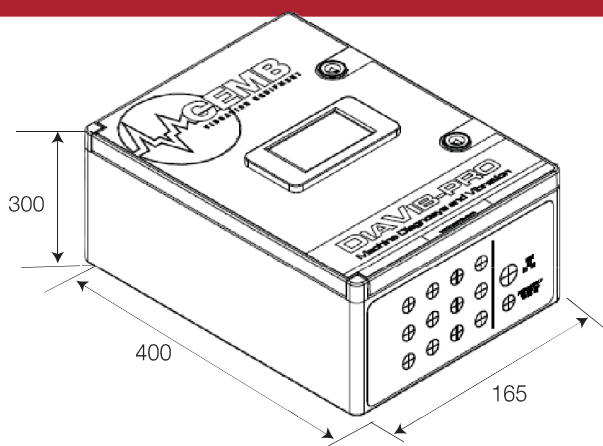





*Note: In the case of a modem, the SIM card is not included and must be provided by the customer.

FEATURES FOR INSTALLERS



Power Supply	110 - 230 VAC (1A) - 50/60 Hz
Dimensions	400x300x165mm
Material	ABS and polyester
Resistance chemicals/UV	Excellent
Color	RAL 7035 grey
Protection	IP 54
Temperature	- 35° ÷ -70°C

Assemble and configure your DIAVIB - PRO system

Component	Description	Order code
	DIAVIB-PRO Control unit Control unit for machine/plant diagnosis. The standard configuration includes the management of two CUBE sensors (to be purchased separately). The system can be expanded to manage up to eight CUBE sensors locally.	DIAVIB-PRO
	DIAVIB Basic Cable Gland Kit The kit includes 3 standard cable glands + 1 Ethernet wall pass-through.	87SE085130
	CUBE Triaxial vibration sensor for machine diagnostics. See CUBE data sheet for available models, cables, and related accessories.	CUBE/0/0/0/0
	DIAVIB Expansion Kit for every 2 additional CUBES Includes CUBE SWITCH dual-channel, terminal blocks, and related cable glands to manage 2 additional CUBES beyond the standard ones.	87SE085131

Individual Components for Existing Panels

CEMB provides basic components for customized installation, for example, in existing machine or plant panels.

	VIB-EDGE VIB-EDGE device for data acquisition, storage, multiprotocol communication & IoT.	9804000167
	VIB-EYE 4.3" touch display panel for the visualization of vibration values and alarm thresholds.	9801000119
	CUBE-SWITCH Dual-channel Ethernet SPE-RJ45 switch for DIN-rail mounting.	39IN078970

Subscription CLOUD

	CLOUD Annual subscription to the CLOUD service	VS9001250
--	---	-----------